



Let's Connect



TPT: <https://www.teacherspayteachers.com/Store/Read-Write-Transform>
Instagram: <https://www.instagram.com/readwritetransform>
Pinterest: <https://www.pinterest.com/readwritetransform>
E-mail: readwritetransform@gmail.com

Thank you for downloading this resource. We hope you and your students enjoy it and benefit from it. If you have any questions, feedback, or comment, please do not hesitate to contact us.

Terms & Conditions

© 2018 Read Write Transform. All rights reserved. This product is for classroom and personal use only and the product is to be used by the original downloader only. Duplication and distribution of this product for other classrooms, teachers, departments, school, or school system is forbidden. It is a violation of the Digital Millennium Copyright Act (DMCA) if this product is distributed or displayed digitally for public view.

About this package

We all have questions, children and adults alike. The "Why?" series is developed to help ignite young children's curiosities about things in the world. Through a series of why questions, students in grades 1 to 3 learn to pick out important information, understand the meaning of three new words per lesson, and practice answering comprehension questions. Each lesson comes with a game to make learning engaging and fun!

The bundle covers the following questions and 4 pages of worksheets and activities:

- Why should I brush my teeth?
- Why should I go to the bathroom?
- Why should I wash my hands?
- Why should I take a shower?
- Why should I floss my teeth?

product features

What to look for

Annotations for 'What to look for':

- The question in focus
- Reading Passage
- Difficult words are bolded
- Students read and color to build fluency
- Clear Reading Markers
- How to close read
- A picture to color

© Teacher of third

I Can Explain

Students explain the question in focus in their own words. For grade 1 and for some grade 2 I would write with them.

© Teacher of third

Do I Understand?

© Teacher of third

Let's Learn New Words

© Teacher of third

like this product?

Check our reading comprehension activities on animals.

Students learn about:

- Why do lions roar?
- Why do zebras have stripes?
- Why do monkeys love bananas?
- Why do elephants have big ears?
- Why do giraffes have long necks?
- Why do lions form prides?
- Why do bears hibernate in the winter?
- Why do kangaroos hop?

IT IS FREE!



Name: _____ Date: _____



Why should I brush my teeth?

Your teeth are protected by a hard **outer** coating. When you eat, the sugar in your food gets stuck on your teeth. The bacteria love to eat sugar. Bacteria are tiny little things that are in your mouth. When you don't brush, the bacteria eats the sugars and they **produce** waste that is called acid. This acid slowly creates holes in your teeth. This is called a **cavity**. Oh no! A cavity hurts a lot and it destroys the tooth. So, you have to brush your teeth to get rid of sugar. If there is no sugar, there is no food for the bacteria. If there is no food for the bacteria, there is no acid. Of course, without acid, your teeth stay healthy.

Close Reading Marks:

Unknown words

Important words

Main Idea

? I don't understand

😊 This reminds me of a story

! Wow. Very interesting

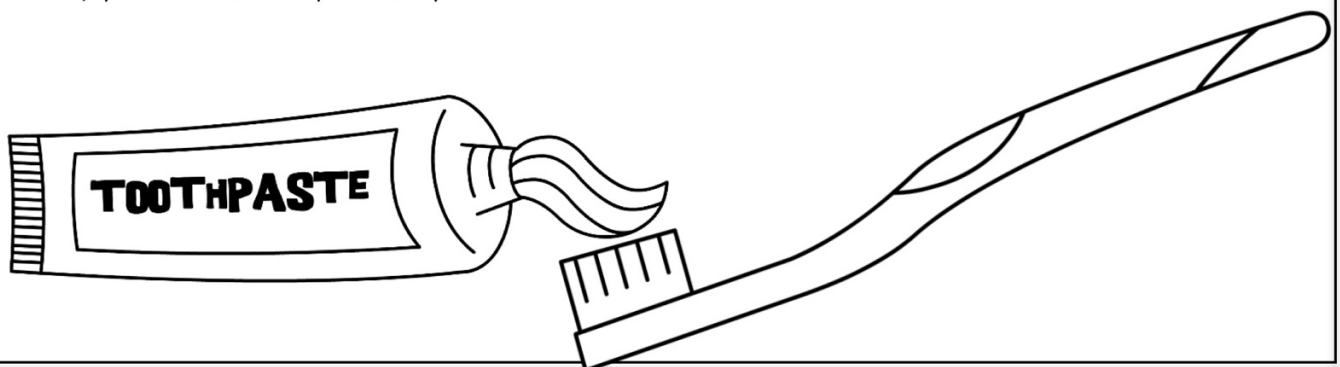

Name: _____ Date: _____

WHY do you have to
brush your teeth?

Handwriting practice lines consisting of a solid top line, a dashed middle line, and a solid bottom line, repeated multiple times for writing.

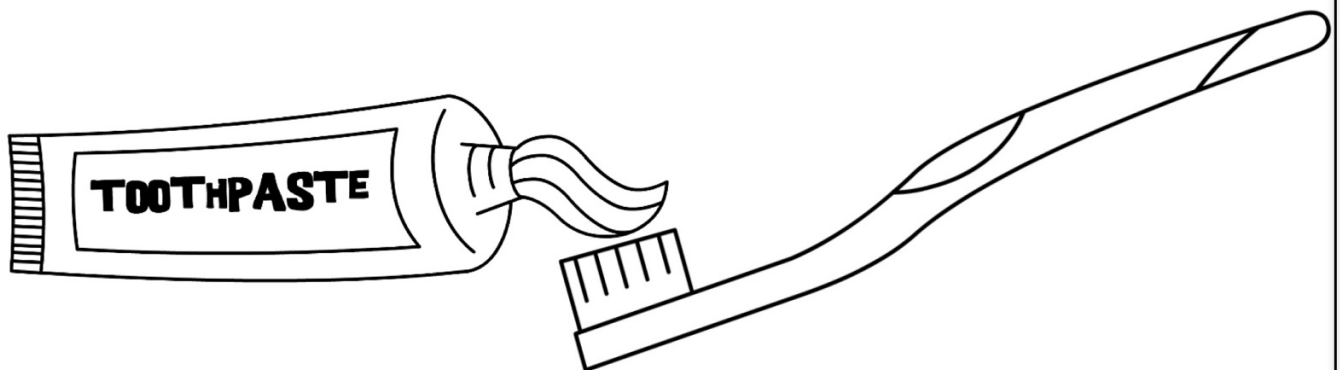

Name: _____ Date: _____

Comprehension Questions

1. Where does the sugar in your food get stuck when you eat?

2. What does the bacteria make, or produce, when it eats the sugar stuck on your teeth?

3. What does acid do to your teeth?

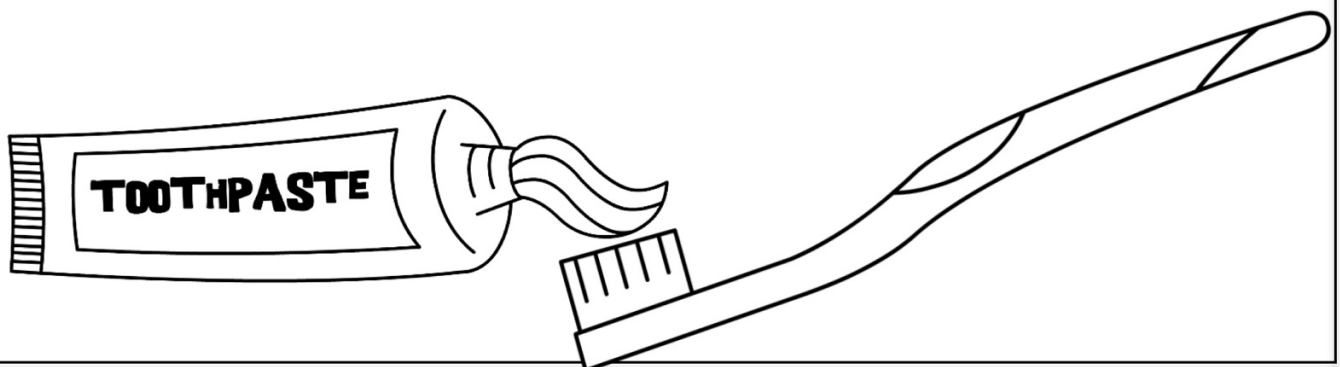

Name: _____ Date: _____

VOCABULARY STUDY

1. From the reading, what do these words mean?

A) Outer is another word for	<input type="radio"/> outside <input type="radio"/> inside
B) Produce means to	<input type="radio"/> remove something <input type="radio"/> create something
C) Cavity is another word for a	<input type="radio"/> hole in your tooth <input type="radio"/> hole in your arm

2. Can you find these words?

- outer
- produce
- cavity

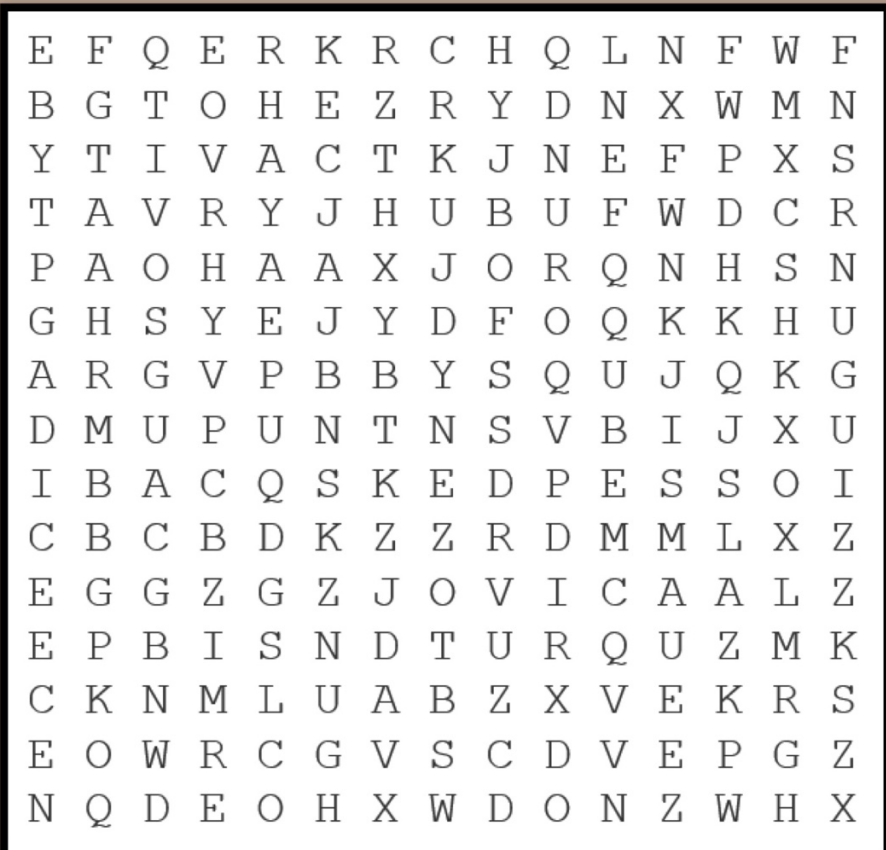
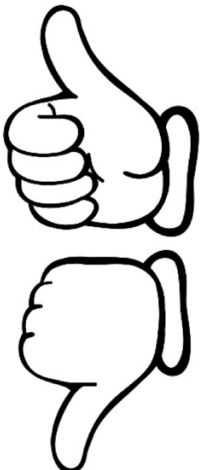

Name: _____ Date: _____



Why do I have to go to the bathroom?

You go to the bathroom to get rid of the leftover **waste** in your body. When you chew on your food, it becomes all mushy. When you swallow it, your body makes it watery –almost like a disgusting soup! Your body likes this because it uses the **nutrients** from it to grow strong and healthy. Of course, your body doesn't want all the food you eat. So, it sends it to your **intestine**. That's where your food becomes solid again. When it has no water left anymore, your body sends it to your bladder, which means only one thing – bathroom time!

Close Reading Marks:

Unknown words

Important words

Main Idea

? I don't understand

😊 This reminds me of a story

! Wow. Very interesting

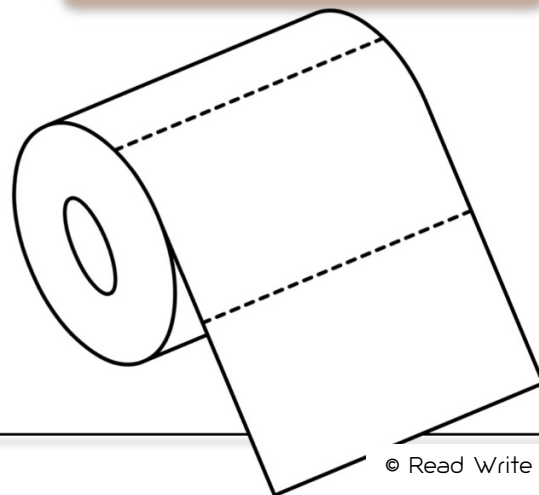

Name: _____ Date: _____

WHY do you have to
go to the bathroom?

Handwriting practice lines consisting of multiple sets of solid top and bottom lines with a dashed midline.

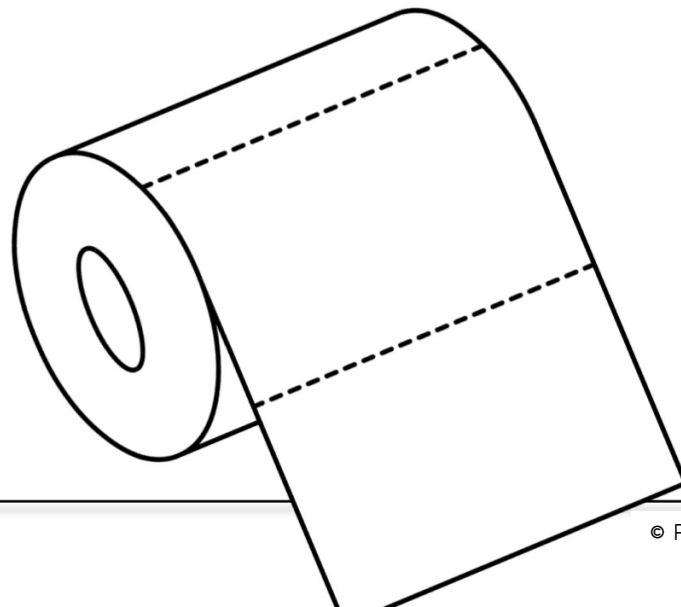

Name: _____ Date: _____

Comprehension Questions

1. Why does your body turn food into a liquid, almost like a soup, when you swallow?

2. Where does the food go when your body doesn't want it?

3. Why does the food become solid again when your body doesn't want it?

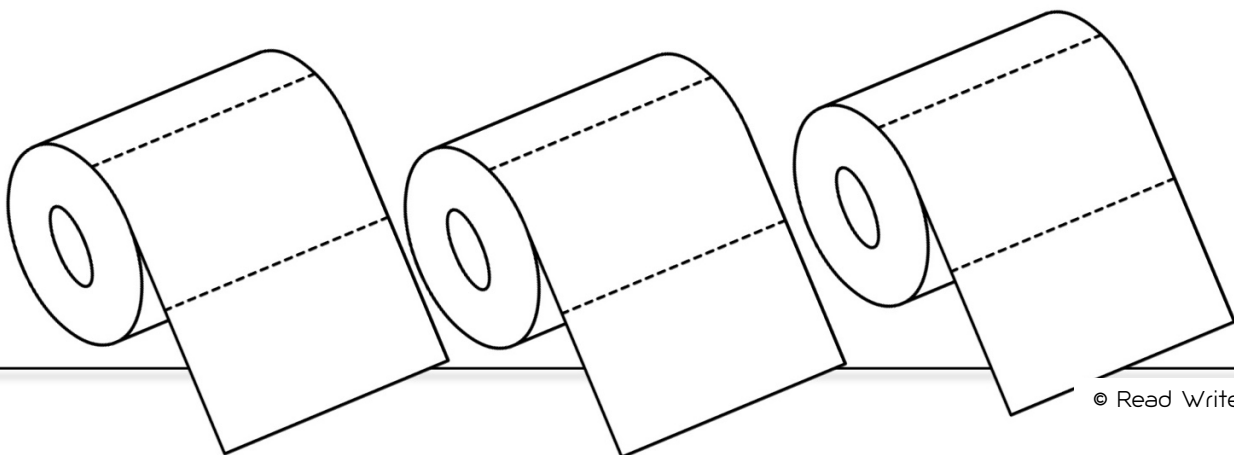

Name: _____ Date: _____

VOCABULARY STUDY

1. From the reading, what do these words mean?

A) Nutrients are important things your body	<input type="radio"/> needs <input type="radio"/> throws away
B) Intestine is a part of your	<input type="radio"/> body <input type="radio"/> food
C) Waste is another word for	<input type="radio"/> solid <input type="radio"/> leftover

2. Can you find these words?

- nutrients
- intestine
- waste

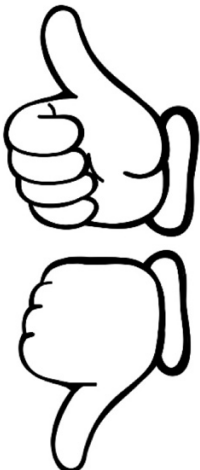

Name: _____ Date: _____



Why should I **shower**?

After a long day of school and play, **bacteria** and **germs** from the things you touched throughout the day grows on your body. They hide inside dark and warm places in your body, like your armpits and in between your fingers. You have to wash your body with soap and water to get rid of these bacteria and germs. If you don't, they grow and grow. **Eventually** they will enter your body. Once it is inside your body, it can make you sick. Also, it can make you really stinky! So much so that you might even make the dog run away.

Close Reading Marks:

Unknown words

Important words

Main Idea

? I don't understand

☺ This reminds me of a story

! Wow. Very interesting



Name: _____ Date: _____

WHY do you have to shower?

Handwriting practice lines consisting of a solid top line, a dashed middle line, and a solid bottom line, repeated ten times.



Name: _____ Date: _____

Comprehension Questions

1. What grows on your body after a long day of work and play?

2. Where do germs and bacteria like to hide?

3. What do germs and bacteria do to you when it is inside your body?



Name: _____ Date: _____

VOCABULARY STUDY

1. From the reading, what do these words mean?

A) One-celled creatures that get nutrients from their environment	<input type="radio"/> bacteria <input type="radio"/> virus
B) Eventually	<input type="radio"/> in the end <input type="radio"/> in the beginning
C) Germ	<input type="radio"/> a tiny organism that causes a disease <input type="radio"/> a tiny organism that helps fight infections

2. Can you find these words?

- bacteria
- germ
- eventually

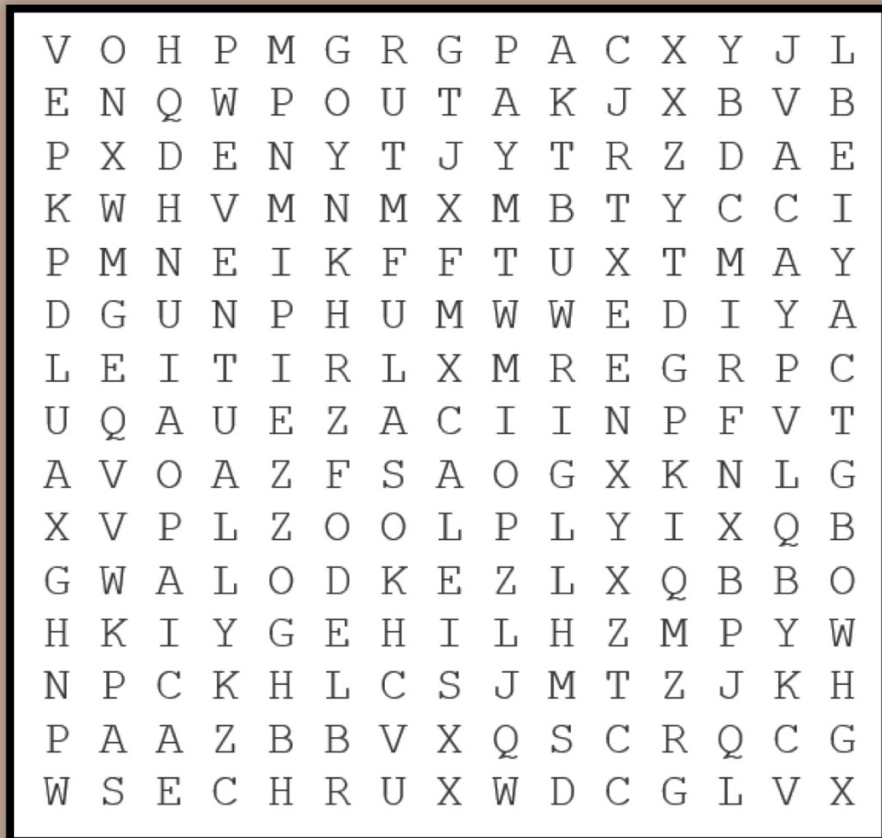
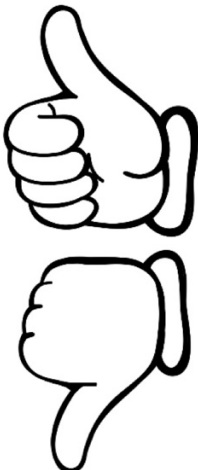

Name: _____ Date: _____



Why should I **wash my hands**?

Your hands are very important! You use them all the time. I bet you are using them right now to hold a pencil or this paper. **Believe** it or not, this paper and your pencil have bacteria on them. When you **continue** to touch things like your hair, your friend's hand, or the **disgusting**, old bathroom door, you get a lot of bacteria on your hands. When you touch your eyes or you eat something with your dirty hands, the bacteria gets inside your body, making you very sick. So, you have to wash your hands with soap and water to get rid of all the bacteria, especially before you eat!

Close Reading Marks:

Unknown words

Important words

Main Idea

? I don't understand

😊 This reminds me of a story

! Wow. Very interesting

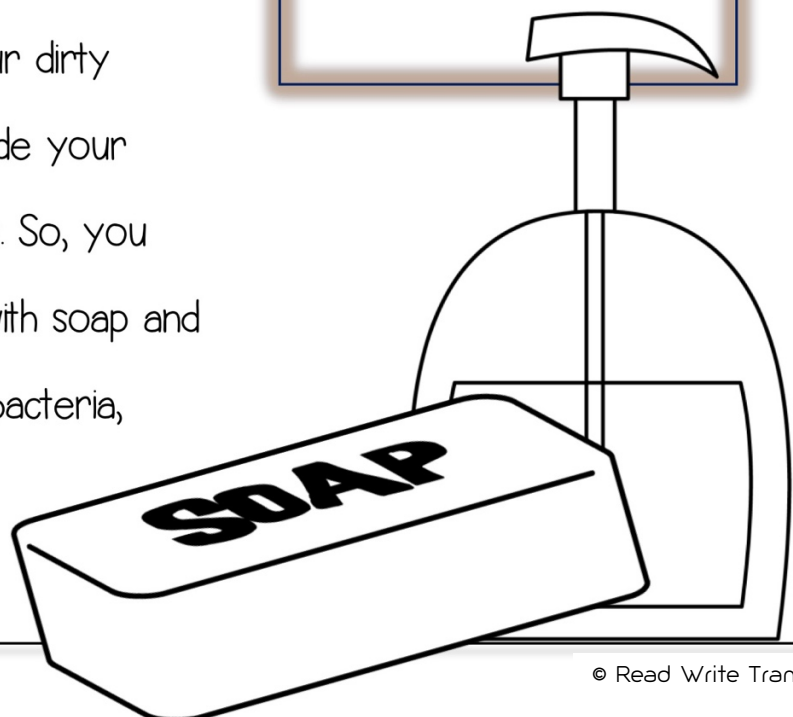

Name: _____ Date: _____

WHY do you have to
wash your hands?

Handwriting practice lines consisting of multiple sets of solid top and bottom lines with a dashed midline.

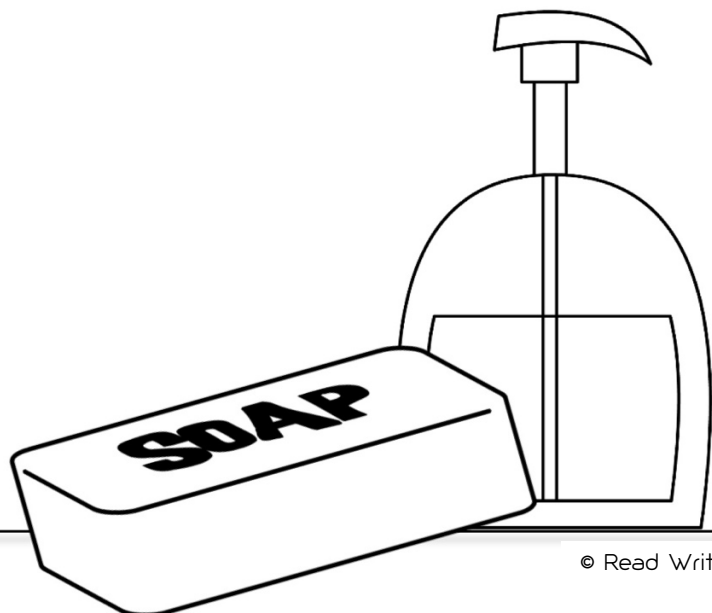

Name: _____ Date: _____

Comprehension Questions

1. Can you give an example of something that has germs or bacteria on it?

2. Where do the germs and bacteria on your hands come from?

3. What are two ways that germs and bacteria can enter your body?

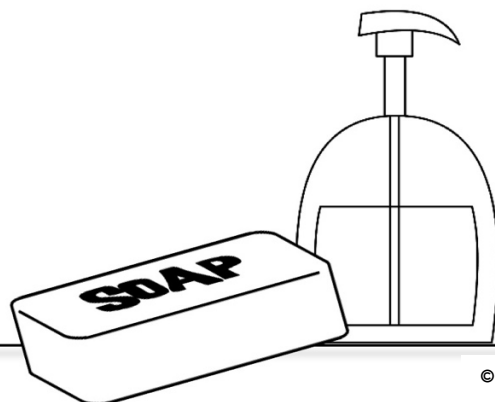

Name: _____ Date: _____

VOCABULARY STUDY

1. From the reading, what do these words mean?

A) Believe is another word for	<input type="radio"/> trust <input type="radio"/> lie
B) Continue means to keep	<input type="radio"/> stop <input type="radio"/> going
C) Disgusting is another word for	<input type="radio"/> clean <input type="radio"/> filthy

2. Can you find these words?

- believe
- continue
- disgusting

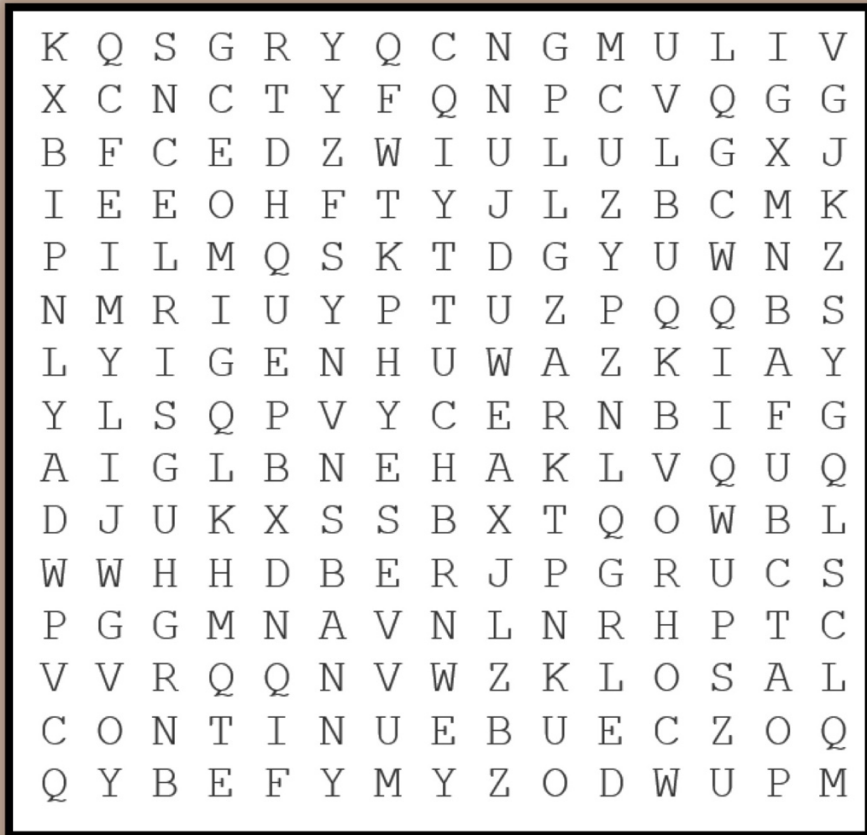
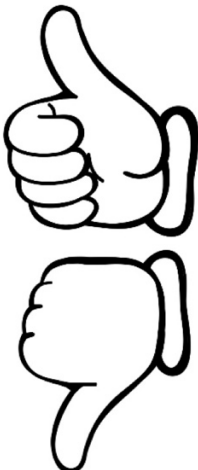

Name: _____ Date: _____



Why should I **floss my teeth**?

There are very tiny spaces between your teeth. When you eat, tiny pieces of food get **stuck** there. Even if you brush your teeth, the food doesn't come off. You have to use a dental **floss** to get all the tiny pieces of food out. If the food is left in between your teeth for a long time, bacteria starts to build up. This is called **plaque**. It is sticky but you can't see it. If it continues to build up, your gums will start to hurt. Then, you can't eat your favorite foods without yelling, "OUCH!"

Close Reading Marks:

Unknown words

Important words

Main Idea

? I don't understand

☺ This reminds me of a story

! Wow. Very interesting

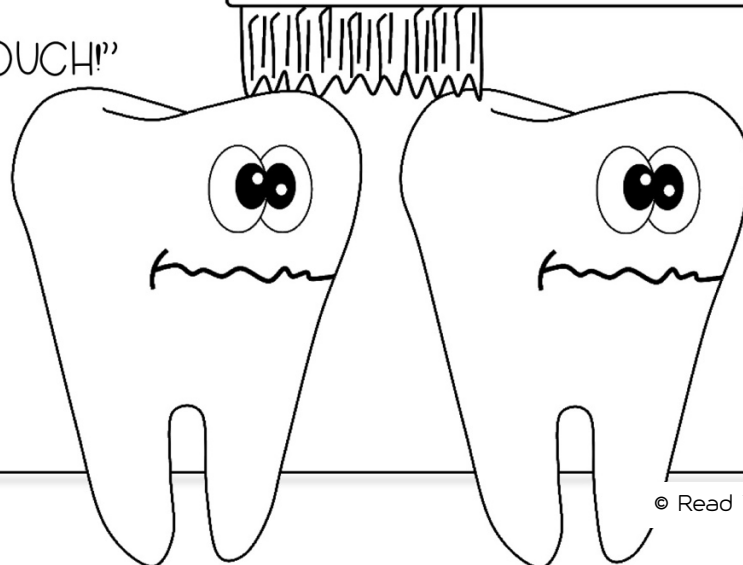

Name: _____ Date: _____

WHY do you have to floss your teeth?

Handwriting practice lines consisting of multiple sets of three horizontal lines (top, middle, bottom) for writing.

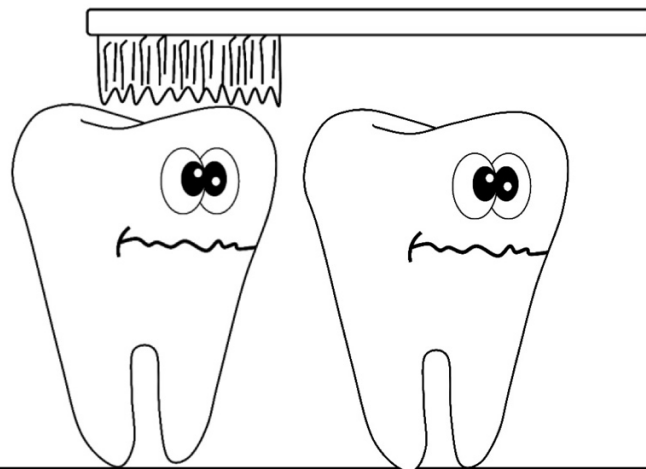

Name: _____ Date: _____

Comprehension Questions

1. Where do tiny food pieces get stuck in your mouth?

2. How do you get the tiny food pieces in between your teeth out?

3. What happens when food is left in between your teeth for too long?

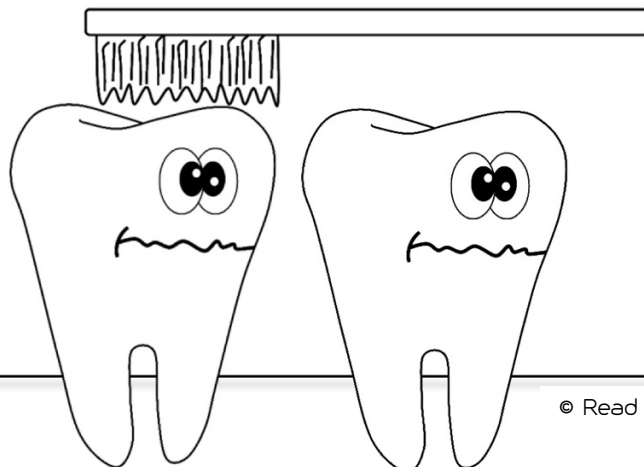

Name: _____ Date: _____

VOCABULARY STUDY

1. From the reading, what do these words mean?

A) When something is stuck, it can't	<input type="radio"/> sleep <input type="radio"/> move
B) Floss is string that helps remove food from	<input type="radio"/> between your teeth <input type="radio"/> between your toes
C) Plaque refers to the sticky things in your teeth	<input type="radio"/> in which bacteria grows <input type="radio"/> that is healthy

2. Can you find these words?

- stuck
- floss
- plaque

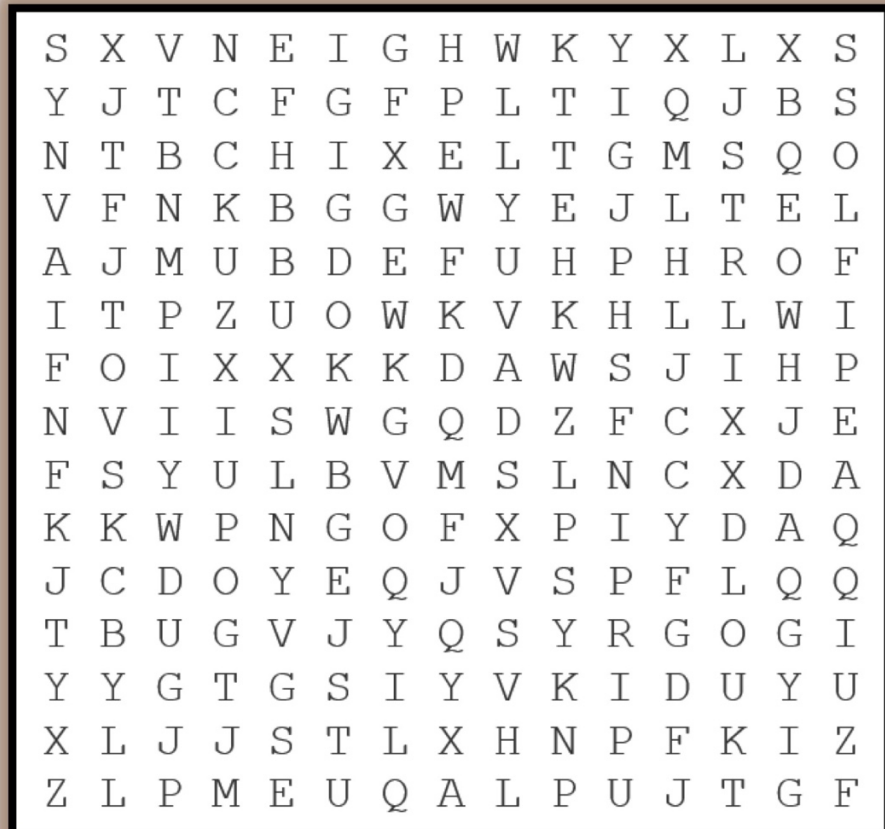
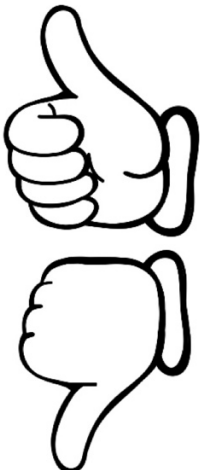

Thank you for downloading this resource. We hope you and your students enjoy it and benefit from it. If you have any questions, feedback, or comment, please do not hesitate to contact us.



TPT: <https://www.teacherspayteachers.com/Store/Read-Write-Transform>
 Instagram: <https://www.instagram.com/readwritetransform/>
 Pinterest: <https://www.pinterest.com/readwritetransform>
 E-mail: readwritetransform@gmail.com

THANK YOU

Your generosity is well appreciated

[Guilherme Jose Drawings](#)

[Worksheet Junkie](#)

[Colleen Alaniz](#)

[Krista Wallden](#)

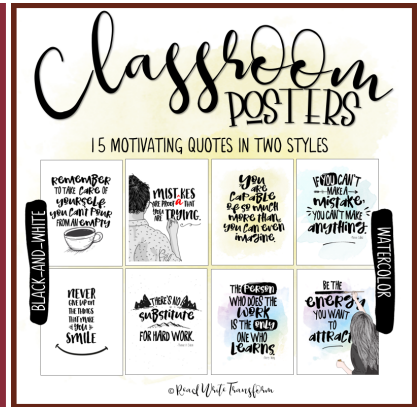
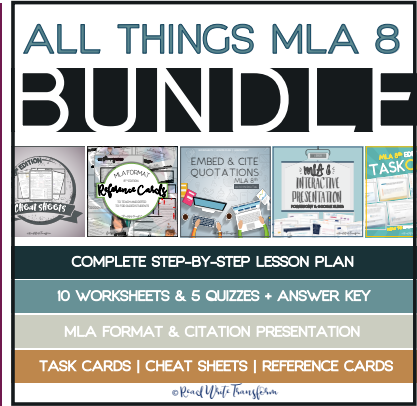
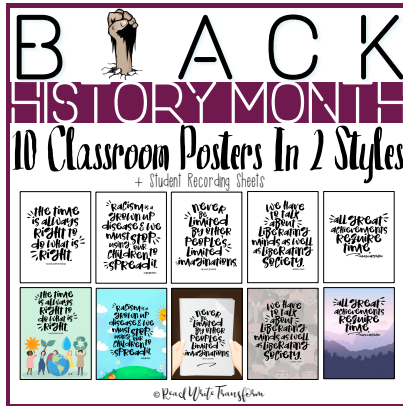

<http://bit.ly/readwritetransform>

Other Resources You Might Like:

Terms & Conditions

© 2018 Read Write Transform. All rights reserved. This product is for classroom and personal use only and the product is to be used by the original downloader only. Duplication and distribution of this product for other classrooms, teachers, departments, school, or school system is forbidden. It is a violation of the Digital Millennium Copyright Act (DMCA) if this product is distributed or displayed digitally for public view.